

BECAS de PROYECTOS

- **CONTROL DE SISTEMAS A TRAVÉS DE REDES DE COMUNICACIÓN.**
- Perfil: Ingeniero Industrial, Telecomunicación, Automática y Electrónica Industrial, con proyecto Fin de Carrera terminado.

Entregar curriculum a:

Francisco Rodríguez Rubio

Dpto. Ingeniería de Sistemas y Automática

y/o enviar a: rubio@esi.us.es, Sevilla, Mayo de 2006

Ph.D. Proposal on Control and Coding co-design in Networked Controlled Systems

Francisco R. Rubio,¹

Candidates for a Spain government scholarship of 4 year duration. The project involves to study new problems of coding and control co-design. Background in theory of control, and communications systems or theory of information is required.

International context. Networked Controlled Systems (NCS) is a new and fast expanding research area in the field of control system theory. It has recently been rated one of the fourth more important topics in the last 2004, CDC Conference, and qualified as a priority topic by several Europeans and USA panel reports, see for instance [8].

Local context. The Group of Automatic, Control and Robotic (TEP-201) initiated a project on the area of NCS in 2005, in collaboration with the Prof. Carlos Canudas-de-Wit at Laboratory of Automatic Control, Grenoble, France. A tele-operated vehicle is under construction. This set-up will serve as a main demonstrator for the proposed projet. The thesis work will be realized within this context.

Problem description. The thesis works aims at studying different aspects of the use of differential coding as a mean for transmitting sensing signals in feedback controlled linear systems interconnected through some transmission network, as shown in Figure 1. The problem is of interest in the area of Networked Controlled Systems (NCS), where we can find several applications calling for data-compression algorithms aiming at reducing the amount of information that may be transmitted throughout the communication channel, and therefore allowing for a better resource allocation and/or for an improvement of the permissible closed-loop system bandwidth (data-rate).



Figura 1: Block diagram of the differential coding in the feedback loop.

There exists a large class of source coding aiming at compressing information for a more effi-

¹Depto. Ingeniería de Sistemas y Automática. Escuela Técnica Superior de Ingenieros. Univ. de Sevilla. Spain. Email: rubio@esi.us.es.

ciently data transmission. Differential coding (DC) belongs to the temporal waveform coding algorithms class. In differential coding, each sample of the waveform is encoded independently of each other, and differences between successive samples are encoded rather than the samples themselves. Since differences between samples are expected to be smaller than the actual samples amplitudes, fewer bits are required to represent the differences.

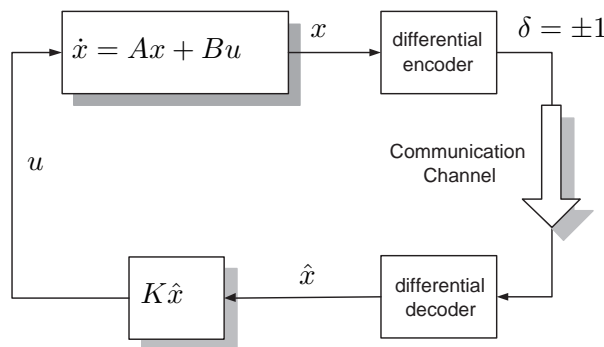
Delta modulation ($\Delta - M$) is the simplest form of the Differential coding, in which a two-level (1-bit) quantizer is used in conjunction with a first-order predictor. Its limitations (slope overloads and granular errors) and its extensions (gain adaptation) are relatively well assessed when this coding is used in open-loop. In the context of NCS, as shown in Figure 1, the algorithm is in feedback connection, and the potential limitation may lead to system instabilities.

Previous works. Quantized feedback design, is a current topic of interest in the NCS field, see for instance [7], [2], [6], [9], [3], [5]. The problem of linear system stabilization under sampled encoded measurements was studied in [2]. The authors derive a explicit relation between the number of quantization levels and the open-loop system characteristic including the sampling period. The quantizer incorporates an adjustable “zoom-out/zoom-in” mechanism. This results in a hybrid control law, in which discrete transitions are triggered by the values of a suitable Lyapunov function.

Static non-uniform quantization is also possible; in [7] the authors characterize the coarsest, or least dense, (largest spacing between levels) logarithmic quantizer over all quadratic control Lyapunov functions. Logarithmic law for quantization is known in the communication field as the logarithmic compressors-expandors, termed a compandor, see [4] for instance.

More recently, time-invariant, memoryless quantizers of the logarithmic type, were also used in [3]. Their study was formulated under a more elaborated two-ways communication set-up. They also allowed for multiple nodes to receive a single message at the same time without extra data rate.

When the sampling period is fixed, the maximum allowed data-rate depends to the number of quantization levels. However, this rate need not be fixed. The problem of digital finite communication bandwidth control (DFCB), can be also formulated so as to accommodate time-varying data-rate constraints due to network asynchronism [5]. In this framework, authors of [5] shown that binary control represents a robust quantization alternative.

Besides the aspect related to variable sampling time, much of the previous works in this area deals with static quantization type, while explicit dynamic quantizers have been scarcely investigated.²

²In [6], the term dynamic quantizer is used to design the fact that the quantization rule of the proposed encoding/decoding algorithm changes over time. The “zoom-out/zoom-in” rule in [2] is also dynamic, but not explicit formula is available.

Proposed work. The $\Delta - M$ algorithm is a two-level dynamic quantizer, which can be seen as the coarsest dynamic quantizer, although this does not necessarily mean that the $\Delta - M$ encoder yields the minimum data-rate stabilizing control strategy. The dynamic property of the delta modulation, and its variants³ have been mainly designed from the signal transmission perspective, but no much as part of a feedback system.

Just recently, we have investigated the closed-loop properties of the $\Delta - M$ algorithm when used in the feedback loop. Our results in [1] have suggested some modification of the original form of the $\Delta - M$ algorithm to improve the closed-loop properties when used in feedback within the context of NCS. Also for the first time, we have studied the stability properties of the continuous-time and the discrete-time version of this algorithm when used to stabilize open-loop unstable linear systems. The results showed that the stability domain and the resulting precision of the $\Delta - M$ is limited by the position of the largest unstable pole of the system. Although this can be improved by increasing the sampling rate, this possibility is clearly limited by the maximum permissible data transmission rate.

It is known that quantization is not necessary the largest factor contributing to data compression, and hence to high data rates. However, optimization of the quantization levels is mandatory in large-scale systems, and may be of great interest while designing low cost emitter/receptors components [3].

In addition to this, it is also known that high compression rates can only be reached by the use of entropy coding. Entropy coding introduce redundancy and assigns some probability distribution to the events. In that way, the average code length can be reduced. Non uniform sampling features of asynchronous delta modulation points toward the possibility of efficient encoding strategies.

Therefore, in this thesis we aim at studying the closed-loop properties of the asynchronous delta modulation together with variable length-block encoding scheme (i.e. Run-length encoding strategy) in which buffering is only, required at the input. As in [1] we will concentrate first on linear (possible open-loop unstable) systems, but the case of nonlinear systems may also be faced.

One important technical challenge here is to how to relate asymptotic notions from information theory, like average code length, to the stability properties of the resulting system.

To apply these coding algorithms, we will use first one simple laboratory equipment. Then such results will be applied and tested using the tele-operated vehicle PPrear [10].

³Adaptive delta modulation ($A\Delta - M$), and Sigma-Delta modulation ($\Sigma\Delta - M$)

References

1. Canudas-de-Wit C., F.R. Rubio, J. Fornes, and F. Gomez-Estern. Differential coding in networked controlled linear systems. Internal report, 2005.
2. Liberzon D. On stabilization of linear systems with limited information. *IEEE Transaction on Automatic Control*, 48(2):304-307, February 2003.
3. Ishii H. and T. Basar. Remote control of lti systems over networks with state quantization. *System and Control Letters*, (54):15-31, 2005.
4. Proakis J.G. *Digital Communications*. McGraw-Hill, Inc. Series in electrical and computer engineering.
5. Li K. and J. Baillieul. Robust quantization for digital finite communication bandwidth (dfcb) control. *IEEE Transaction on Automatic Control*, 49(9):1573-1584, September 2004.
6. Lemmon M. and Q. Ling. Control system performance under dynamic quantization: the scalar case. In *43rd IEEE Conference on Decision and Control*, pages 1884-1888, Atlantis, Paradise Island, Bahamas, 2004.
7. Elia N. and S.K. Mitter. Stabilization of linear systems with limited information. *IEEE-Transaction on Automatic Control*, 46(9):1384-1400, September 2001.
8. Murray R.M., K.J. Astrom, S.P. Boyd, R.W. Brockett, and G. Stein. Future directions in control in an information-rich world. *IEEE Control System magazine*, April 2003.
9. Tan S., Xi Wei, and J.S. Baras. Numerical study of joint quantization and control under block-coding. In *43rd IEEE Conference on Decision and Control*, pages 4515-4520, Atlantis, Paradise Island, Bahamas, 2004.
10. Fiacchini, M., A. Viguria, R. Cano, A. Prieto, F.R. Rubio, J. Aracil and C. Canudas-de-Wit. Design and Experimentation of a Personal Pendulum Vehicle. Submitted 7th Portuguese Conference on Automatic Control (CONTROLO'06), 11-13, September, Lisboa, Portugal, 2006. (<http://nyquist.us.es/~ppcar/>).